

twin
BEAM²

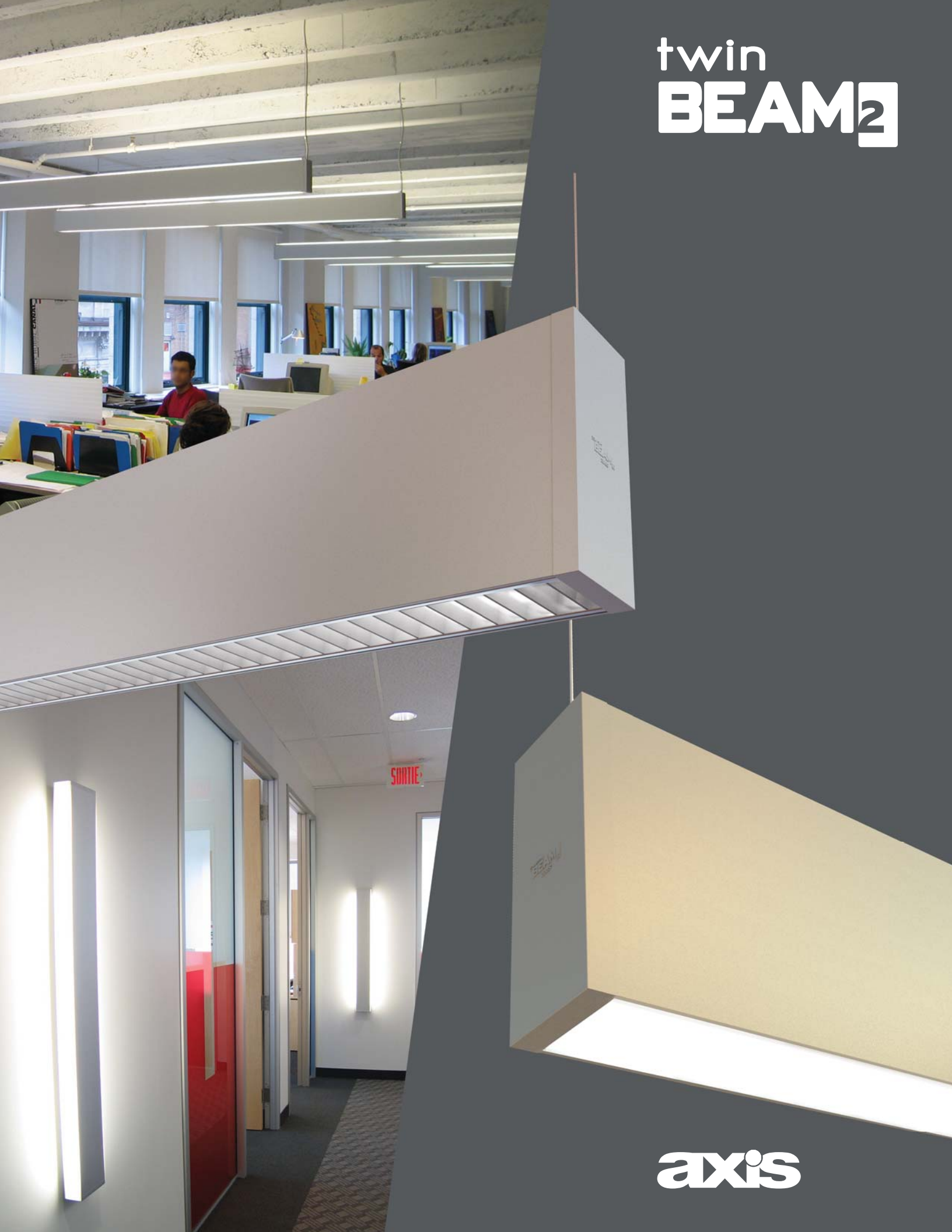

axis

PRODUCT ORDERING CODE

product id	optics length / ft	lamp	lamp config.	MR11	finish	voltage	ballast	circuits	suspension	other	controls	custom	
TB	S	4	T5	2	M0	W	I20	E	I	CA36			
TB pendant +W wall horizontal +V wall vertical	2 3 4 5 6 8 12 S# system	0 zero lamps IU one lamp up ID one lamp down 2 two lamps (1 up / 1 down)	W white A aluminum C custom	E electronic ERS rapid start D dimming (specify details)	CA # cable (36" std) CT# cable / t-bar SA # stem (18" std) (length / inch)	DS daylight sensor OS occ. sensor DOS daylight / occ. sensor	S satin lens F frosted lens PL semi spec para. louver SB white louver A asymmetric reflector	T5 T5HO T8	M# MR11 qty. (add 6" per lamp)	UNV 120 277 347	1 one circuit 2 two circuits +E em. circuit +M + MR11	D dust cover B# batt. pack (quan./4' sections) F fuse (one per ballast)	C custom description

sample ordering options

LAMP CONFIGURATIONS

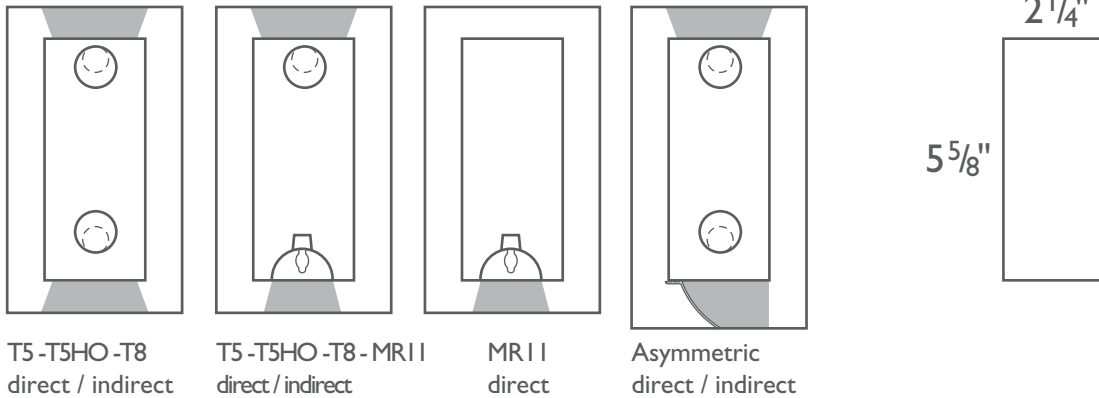

CANDLEPOWER DISTRIBUTION

Twin Beam Direct/Indirect w/Frosted Lens
 Test Lamps: 2 x F28T5 Fluorescent (1 up, 1 down)
 code: **TB-F-4-T5-2-**
 Efficiency : 73%
 Photopia Electronic Simulation

Twin Beam Direct Asymmetric
 Test Lamps: 2 x F28T5 Fluorescent (1 up, 1 down)
 code: **TB-A-4-T5-2-**
 Efficiency : 66%
 Photopia Electronic Simulation

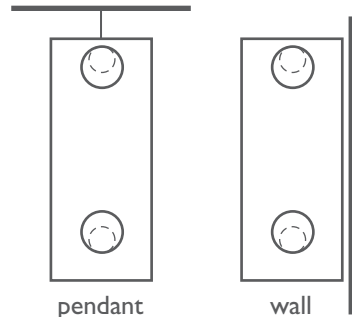
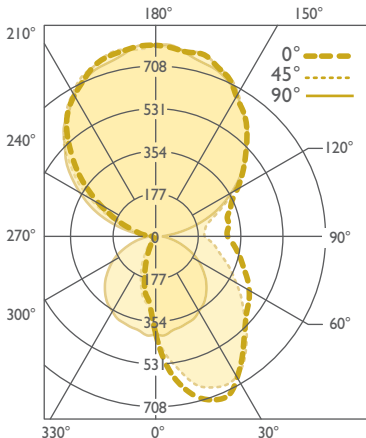
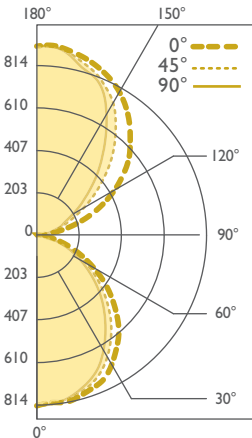

PHOTOMETRICS

Site specific lighting calculations and electronic photometric data are available at www.axislighting.com

Product design and development is an on going process at Axis Lighting. We reserve the right to change specifications. Contact Axis for latest product information.

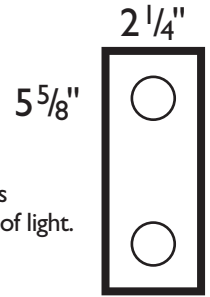

SLIM ARCHITECTURAL DESIGN

With its clean, elegant design and slim profile, the **Twin Beam** fixture can easily fit into many environments including offices, hospitals, and institutions enhancing any architectural space with slender, unobtrusive lines of light.

ALUMINUM PROFILE

The slim **Twin Beam** profile is made of precisely fabricated high grade aluminum, ensuring straight linear fixtures in both short and long system runs.

DIE-CAST END CAPS

Twin Beam die-cast zinc end caps are precision fabricated with invisible fasteners.

OPTICS

While the **Twin Beam** fixture is incredibly small and slim it can hold T5, T5HO as well as T8 lamps and inset MRI I halogen spots.

Twin Beam also offers a variety of optical options including semi-specular parabolic louvers, white louvers, frosted virgin acrylic extruded lenses and our new smooth satin lens.

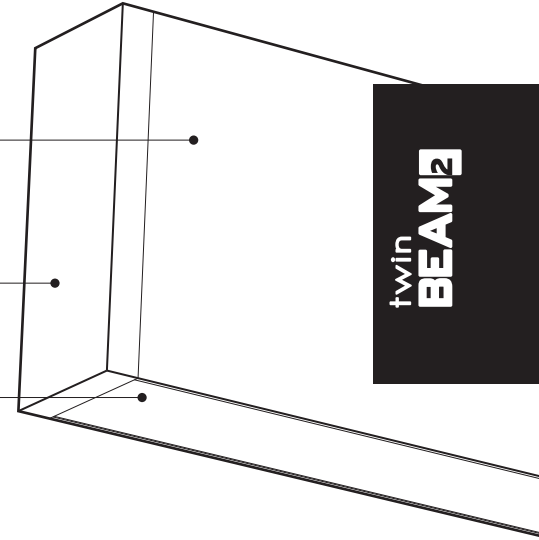

BALLAST & ELECTRICAL

Only the highest quality electrical components are used for added safety, convenience, long term cost and ecological savings.

We offer electronic, dimming and emergency ballasts with voltages of 120, 277 and 347 volts.

The **Twin Beam** is UL listed to meet U.S. and Canadian standards.

LINEAR SYSTEMS

Twin Beam linear systems, with the use of a strong profile, allow for a nearly seamless connection system of continuous runs.

Lengths of 4', 8', 12' as well as custom lengths are available.

INNOVATIVE MODULAR SOLUTION

Twin Beam features a modular system approach allowing a multitude of layout patterns with the use of corners.

Custom corners include:

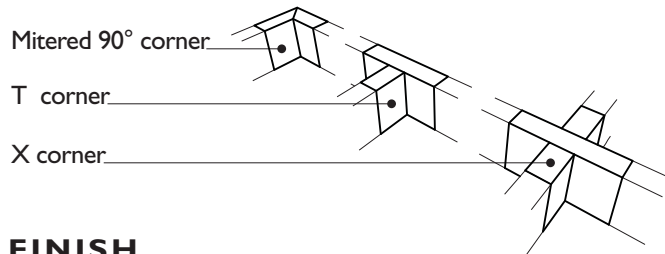

FINISH

The **Twin Beam** can be finished with either an anodized aluminum finish, a powder coated highly reflective white finish or custom color.

NEW FEATURES

SATIN LENS

Our new satin lens made from a blend of highly transmissive material and an extra diffusing compound creates a smooth lens with an even glow available in any configuration.

SENSOR INTEGRATION

Daylight and Occupancy sensors can now be mounted on a blank sheet of extruded aluminum, easily integrating into any of our **Twin Beam** fixture configurations.

VERTICAL MOUNTING

The **Twin Beam** fixture is available in a wide range of mounting options.

Pendant mounting and both horizontal and vertical Wall mounting are available.

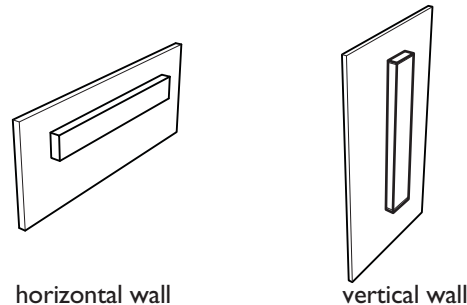

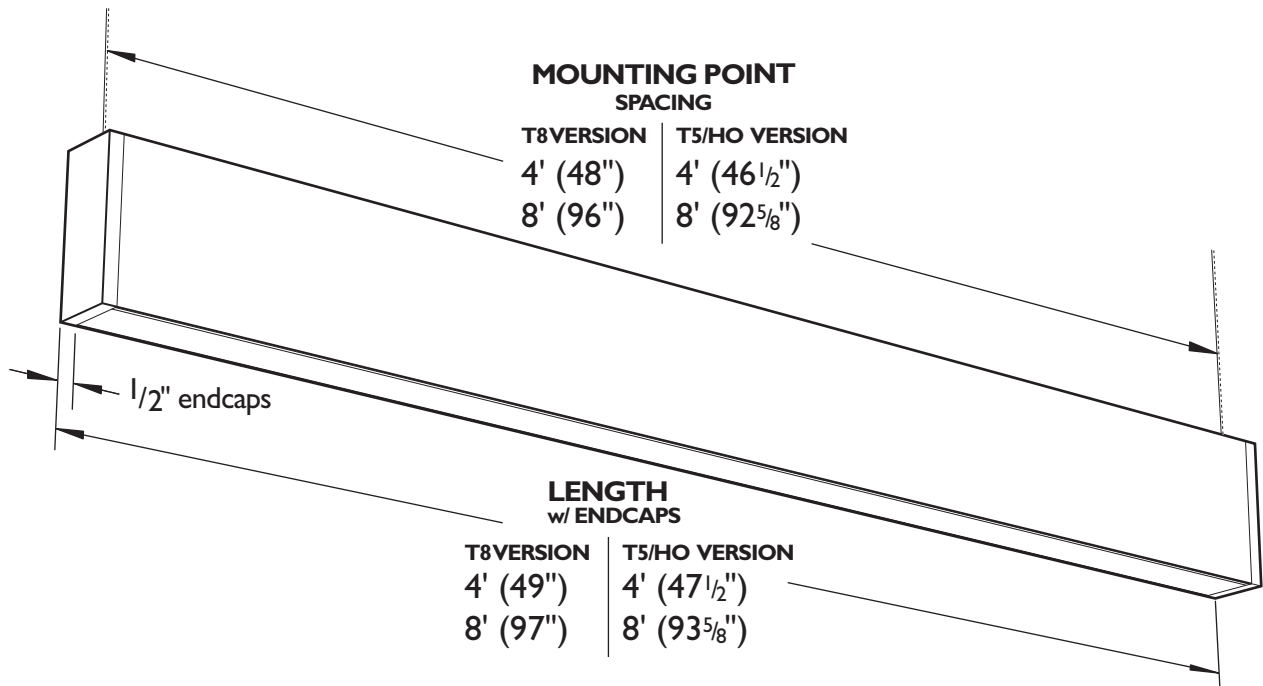

OPTICS

i 4.0 Optics

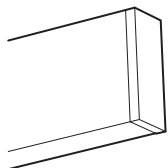

**SATIN LENS
FROSTED LENS**
(acrylic snap-in lens)
satin: 68% transmissive – frosted: 85% transmissive

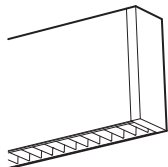

LOUVERS
(semi-spec. parabolic louver or white louver)
9/16" deep blades – 5/8" spacing – 72 blades per 4'

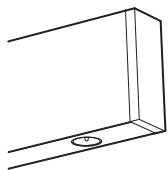

BLANK with MRI I
(6" blank aluminum sections)
* See Twin Beam MRI I Spec sheet.

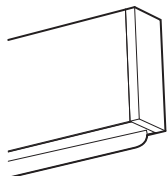

ASYMMETRIC
(asymmetric reflector)
* See Twin Beam Asymmetric Spec sheet.

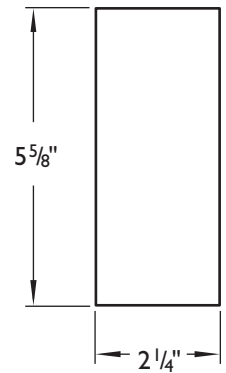

LAMP CONFIGURATIONS

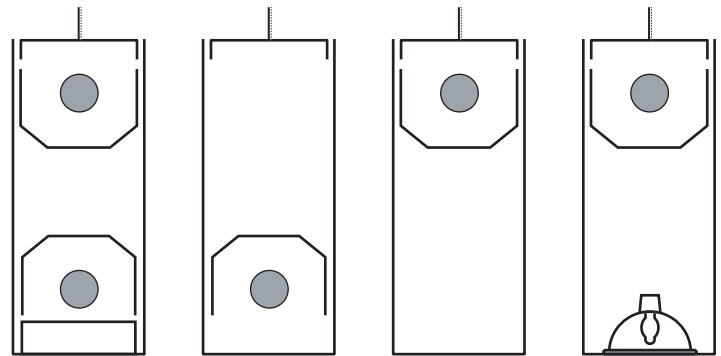

2 x T5
2 x T5HO
2 x T8

1 x T5
1 x T5HO
1 x T8

1 x T5
1 x T5HO
1 x T8

MR II

i DETAILED INFORMATION

for more detailed information, please refer to the info sheets noted above

PENDANT DIRECT / INDIRECT SPECIFICATIONS

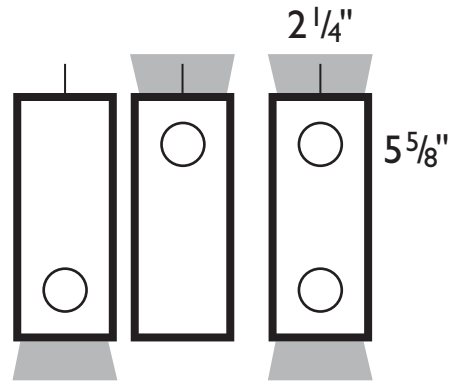

CONSTRUCTION

Housing	Extruded Aluminum (0.075" nominal)
End Cap	Die Cast Zinc (0.080" nominal)
Interior Brackets	Die Formed Sheet Steel (20 gauge)
Reflectors	White Powder Coated Sheet Steel (22 gauge)
Louvers	Die Formed Semi-Specular Aluminum (22 gauge)
White Louver	Die Formed Aluminum Painted White (22 gauge)
Blank	Extruded Aluminum (0.075" nominal)
Lenses	Extruded Acrylic (0.070" nominal) Satin: 68% trans. Frosted: 85% trans.
Hanger	Die Formed Sheet Steel (18 gauge)
Suspension	Aircraft Cable or Ø 1/2" Stem
Cable Grips	Quick Connecting / Release

Finish Anodized, Powder Coated, Lacquered
Weight 16.2 lbs / 7.4 kg (4' fixture)

ELECTRICAL

Ballast Options	Electronic, Dimmable, Emergency
Emergency	Emergency Battery Pack or Circuit
Lamp Options	T5, T5HO, T8
Voltage	120, 277, 347, UNV

Daylight Harvesting / Occupancy Sensors Available

Certification UL listed to U.S. & Canadian standards

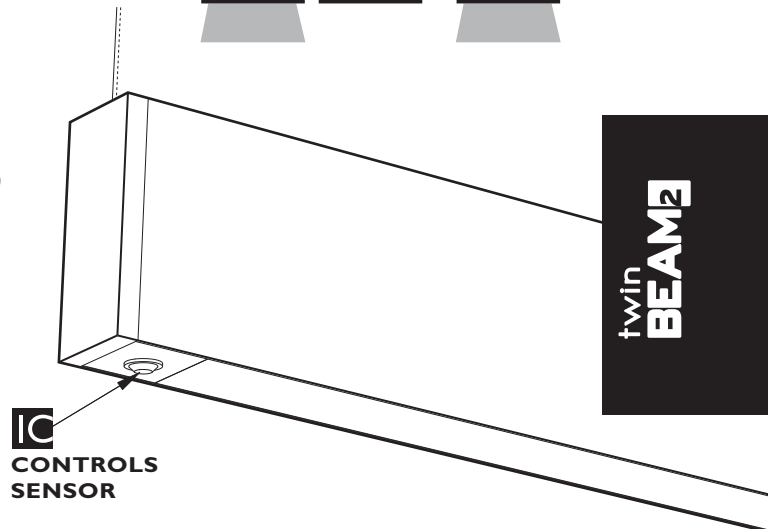

PRODUCT ORDERING CODE

product id	optics	length / ft	lamp	lamp config.	MR11	finish	voltage	ballast	circuits	suspension	other	controls	custom
TB	S	8	T5	2	M0	W	120	E	I	CA36			
TB pendant	S satin lens F frosted lens PL semi spec para. louver SB white louver A asymmetric reflector	8 system	T5 T5HO T8	0 zero lamps 1U one lamp up 1D one lamp down 2 two lamps (1 up / 1 dn)	M# MR11 qty. *(add 6" per lamp)	W white A aluminum C custom	UNV 120 277 347	E electronic ERS rapid start D dimming (specify details)	I one circuit 2 two circuits +E em. circuit +M + MR11	CA # cable (36" std) CT # cable / t-bar SA # stem (18" std) (length / inch)	DS daylight sensor OS occ. sensor DOS daylight / occ. sensor	D dust cover B# batt. pack (quan./4' sections) F fuse (one per ballast)	C custom description if required

i 4.0 Optics
Asymmetric: See Twin Beam Asymmetric Spec sheet.

i 5.0 Control Sensors
 Sensors are mounted on a blank sheet of extruded aluminum.

i 7.1 Installation Instructions
Corners: See Twin Beam Corner Spec sheet.

i 3.3 Mounting Options

DETAILED INFORMATION

for more detailed information, please refer to the info sheets noted above



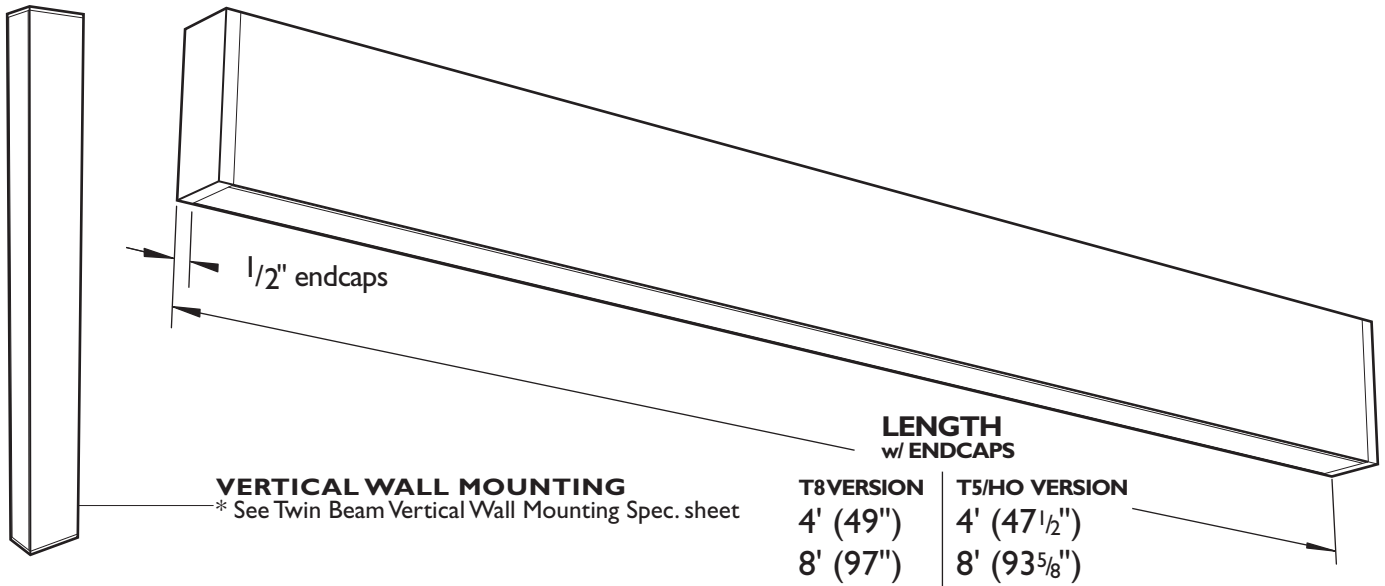
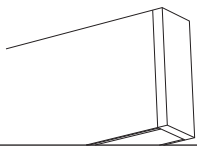

VERTICAL WALL MOUNTING
* See Twin Beam Vertical Wall Mounting Spec. sheet

LENGTH w/ ENDCAPS	
T8 VERSION	T5/HO VERSION
4' (49")	4' (47 1/2")
8' (97")	8' (93 5/8")

OPTICS

i 4.0 Optics

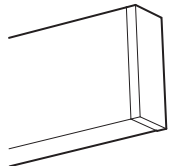

**SATIN LENS
FROSTED LENS**
(acrylic snap-in lens)
satin: 68% transmissive – frosted: 85% transmissive

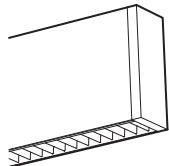

LOUVERS
(semi-spec. parabolic louver or white louver)
9/16" deep blades – 5/8" spacing – 72 blades per 4'

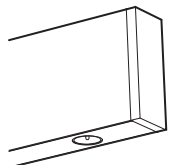

BLANK with MR11
(6" blank aluminum sections)
* See Twin Beam MR11 Spec sheet.

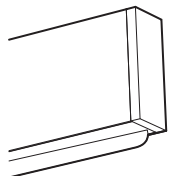

ASYMMETRIC
(asymmetric reflector)
* See Twin Beam Asymmetric Spec sheet.

i MOUNTING DETAILS

7.3 Installation Instructions

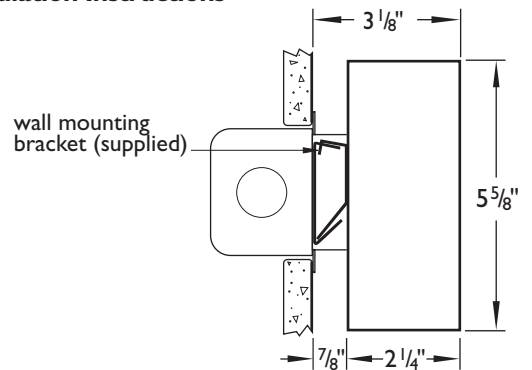

LAMP CONFIGURATIONS

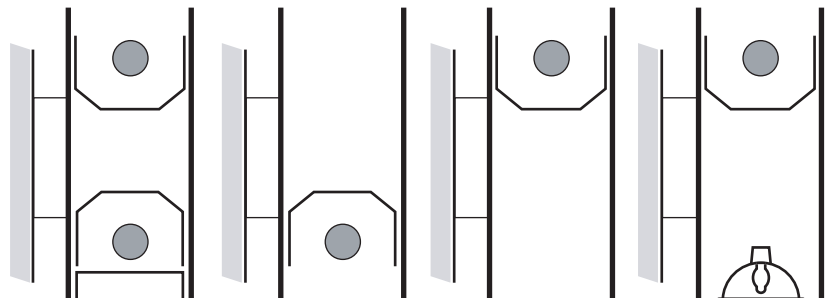

2 x T5
2 x T5HO
2 x T8

1 x T5
1 x T5HO
1 x T8

1 x T5
1 x T5HO
1 x T8

MR11

i DETAILED INFORMATION

for more detailed information, please refer to the info sheets noted above

WALL MOUNT SPECIFICATIONS

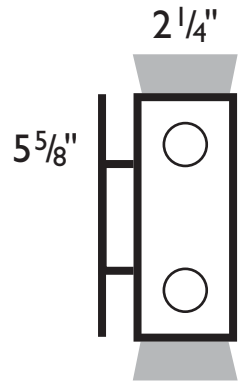

CONSTRUCTION

Housing	Extruded Aluminum (0.075" nominal)
End Cap	Die Cast Zinc (0.080" nominal)
Interior Brackets	Die Formed Sheet Steel (20 gauge)
Reflectors	White Powder Coated Sheet Steel (22 gauge)
Louvers	Die Formed Semi-Specular Aluminum (22 gauge)
White Louver	Die Formed Aluminum (22 gauge)
Blank	Extruded Aluminum (0.075" nominal)
Lenses	Extruded Acrylic (0.070" nominal) Satin: 68% trans. Frosted: 85% trans.
Wall Mount Bracket	Die Formed Sheet Steel (16 gauge)
Finish	Anodized, Powder Coated, Lacquered
Weight	16.2 lbs./ 7.4 kg (4' fixture)

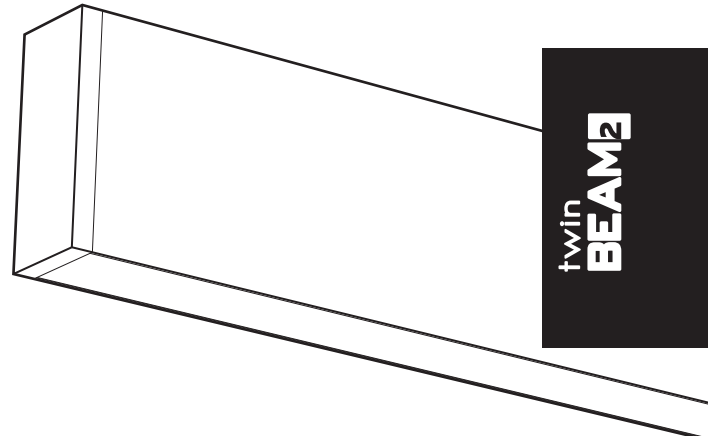

ELECTRICAL

Ballast Options	Electronic, Dimmable, Emergency
Emergency	Emergency Battery Pack or Circuit
Lamp Options	T5, T5HO, T8,
Voltage	120, 277, 347, UNV
Certification	UL listed to U.S. & Canadian standards

WALL MOUNT FEATURES

- A.D.A. compliant
- Small wall footprint
- Minimized mounting brackets
- 10° level adjustment
- Vertical Wall Mounting available
- * See Twin Beam Vertical Wall Mount Spec sheet

PRODUCT ORDERING CODE

product id	optics	length / ft	lamp	lamp config.	MR11	finish	voltage	ballast	circuits	other	custom
TBW	S	8	T5	2	M0	W	120	E	I		
TBW wall horizontal	2 3 4 5 6 8 12 S# system		0 zero lamps IU one lamp up ID one lamp down 2 two lamps (1 up / 1 dn)		W white A aluminum C custom		UNV 120 277 347	E electronic ERS rapid start D dimming (specify details)	1 one circuit 2 two circuits +E em. circuit +M +MR11	D dust cover B# batt. pack (quan./4' sections) F fuse (one per ballast)	C custom description if required
	S satin lens F frosted lens PL semi spec para. louver SB white louver A asymmetric reflector		T5 T5HO T8		M# MR11 qty. * (add 6" per lamp) * Maximum 7 x MR11 lamps per 4' fixture. Provide a sketch for MR11 locations. MR11: See Twin Beam MR11 Spec sheet.						

i 4.0 Optics
Asymmetric: See Twin Beam Asymmetric Spec sheet.

i 7.3 Installation Instructions
Corners: See Twin Beam Corner Spec sheet.
Vertical: See Twin Beam Vertical Wall Mount Spec sheet.

DETAILED INFORMATION

for more detailed information, please refer to the info sheets noted above



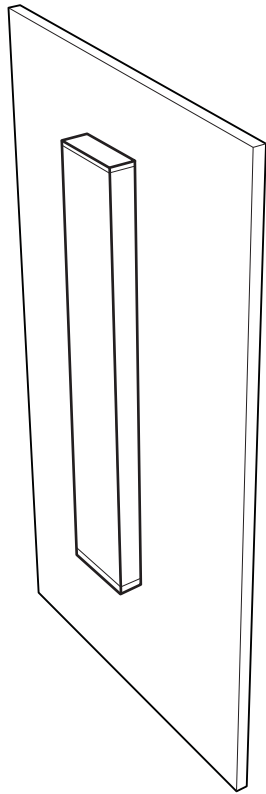
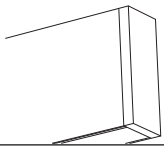

i **VERTICAL WALL MOUNT DETAILS**
7.4 Installation Instructions

wall mounting bracket (supplied)

TOP VIEW

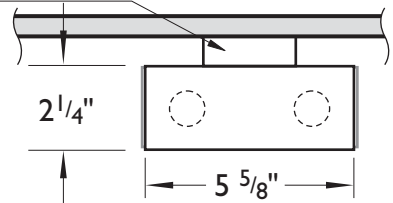

SIDE VIEW

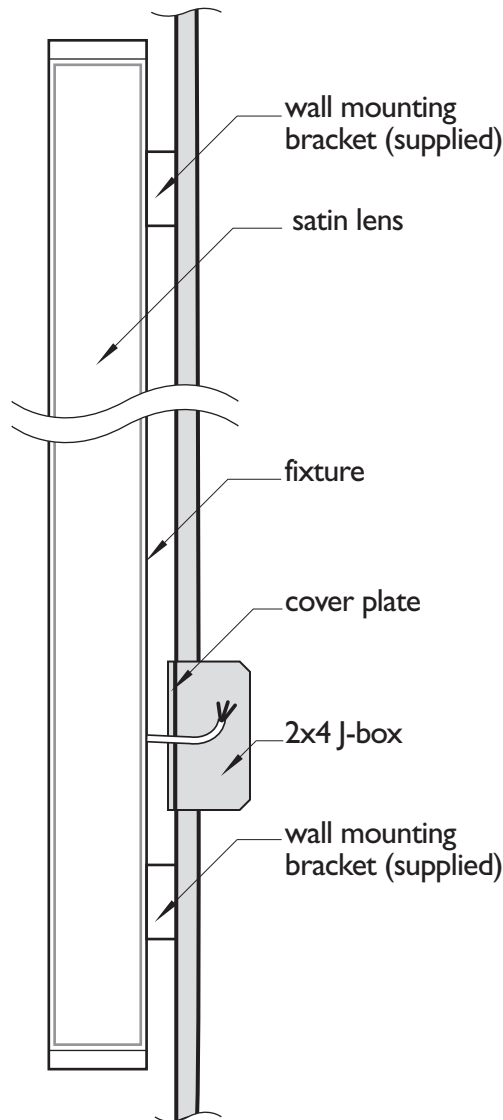

FRONT VIEW

LENGTH
w/ ENDCAPS

3' (37")

4' (49")

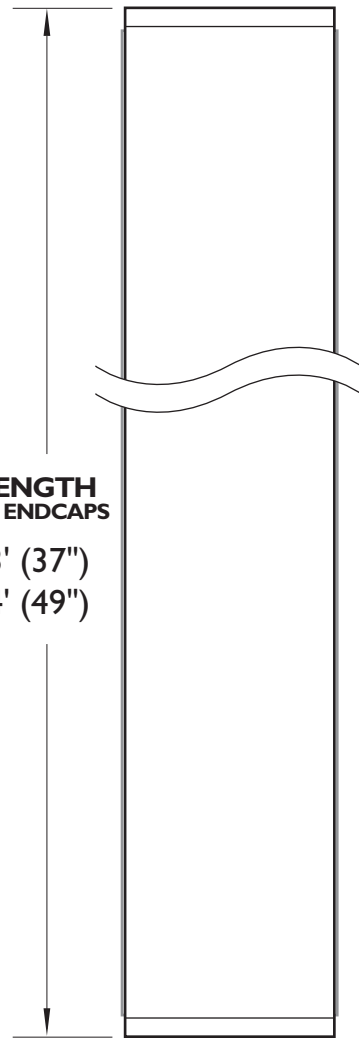

i **DETAILED INFORMATION**

for more detailed information, please refer to the info sheets noted above

VERTICAL WALL MOUNT SPECIFICATIONS



CONSTRUCTION

Housing	Extruded Aluminum (0.075" nominal)
End Cap	Die Cast Zinc (0.080" nominal)
Interior Brackets	Die Formed Sheet Steel (20 gauge)
Reflectors	White Powder Coated Sheet Steel (22 gauge)
Louvers	Die Formed Semi-Specular Aluminum (22 gauge)
White Louver	Die Formed Aluminum Painted White (22 gauge)
Blank	Extruded Aluminum (0.075" nominal)
Lenses	Extruded Acrylic (0.070" nominal) Satin: 68% trans. Frosted: 85% trans.
Wall Mount Bracket	Die Formed Sheet Steel (16 gauge)
Finish	Anodized, Powder Coated, Lacquered
Weight	16.2 lbs. / 7.4 kg (4' fixture)

ELECTRICAL

Ballast Options	Electronic, Dimmable, Emergency
Emergency	Emergency Battery Pack or Circuit
Lamp Options	T5, T5HO, T8,
Voltage	120, 277, 347 UNV
Certification	UL listed to U.S. & Canadian standards

PRODUCT ORDERING CODE

product id	optics	length / ft	lamp	lamp config.	MR11	finish	voltage	ballast	circuits	other	custom
TBWW	S	8	T5	2	M0	W	120	E	I		
TBWW +V	wall horizontal wall vertical	2 3 4 5 6 8 12 S# system	0 1U 1D 2	zero lamps one lamp up one lamp down two lamps	W A C	white aluminum custom	UNV 120 277 347	E ERS D	electronic rapid start dimming (specify details)	D B# F	dust cover batt. pack (quan./4' sections) fuse (one per ballast) C custom description (include sketch)
	S F	satin lens frosted lens	T5 T5HO T8		M# MR11 qty. * (add 6" per lamp)			1 2 +E +M	one circuit two circuits em. circuit + MR11		

* Maximum 7 x MR11 lamps per 4' fixture.
Provide a sketch for MR11 locations.
MR11: See Twin Beam MR11 Spec sheet.

i 4.0 Optics

i 7.4 Installation Instructions

i DETAILED INFORMATION

for more detailed information, please refer to the info sheets noted above



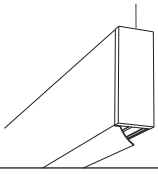

SECTION

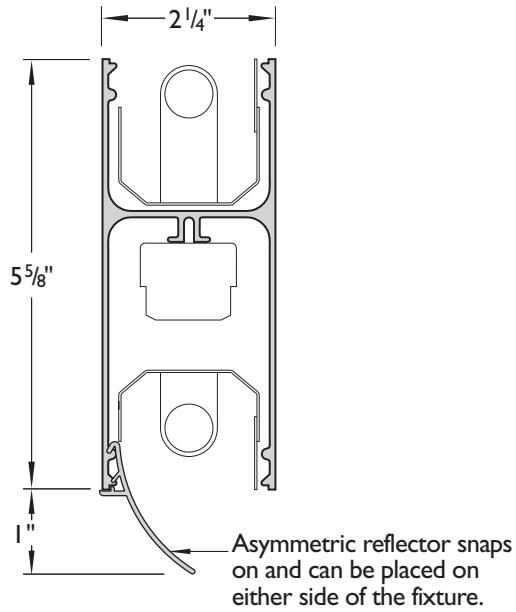

LAMP CONFIGURATIONS

1 x T5
1 x T5HO

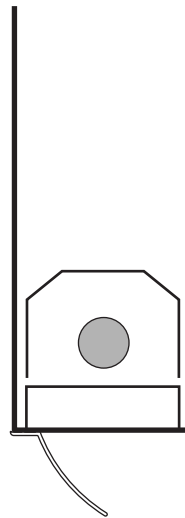

2 x T5
2 x T5HO

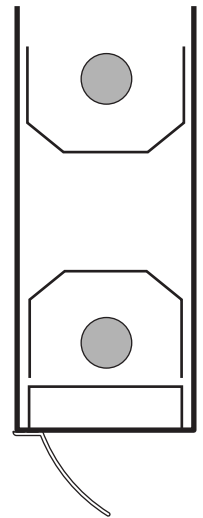

CANDLEPOWER DISTRIBUTION

(Product Code: **TB-A-4-T5-2**)
Test Lamps: 2 x F28T5 Fluorescent
Efficiency : 66%
Photopia Electronic Simulation

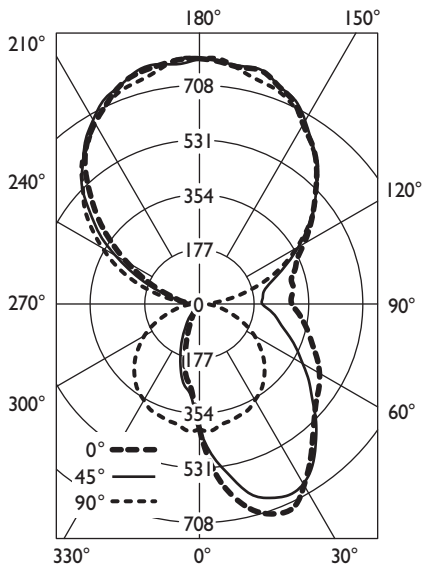

CONFIGURATIONS

Pendant
(Product Code: **TB**)

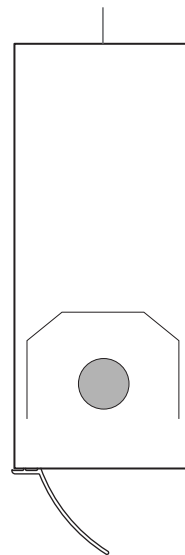

Wall Mount
(Product Code: **TBW**)

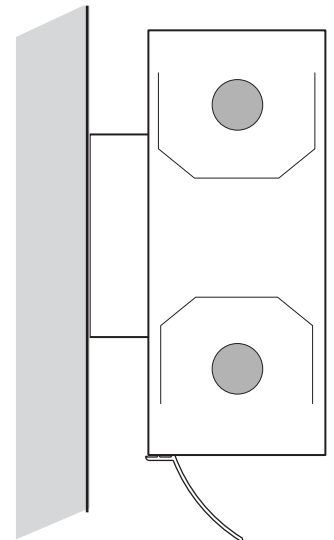

i DETAILED INFORMATION

for more detailed information, please refer to the info sheets noted above

ASYMMETRIC SPECIFICATIONS

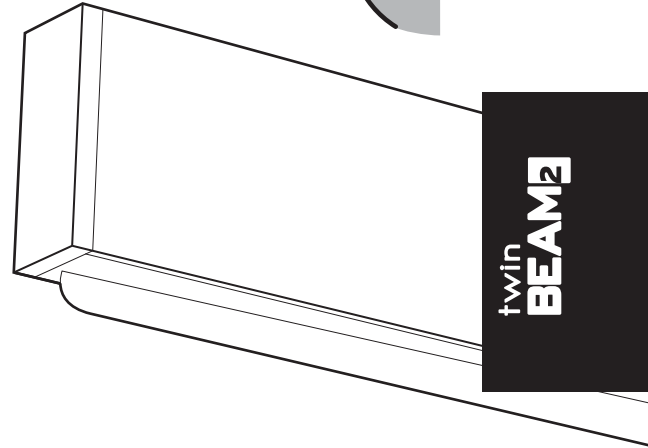
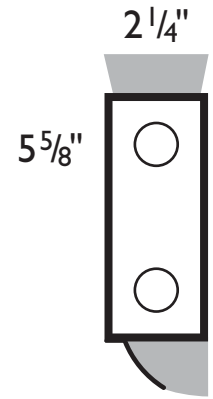

CONSTRUCTION

Housing	Extruded Aluminum (0.075" nominal)
End Cap	Die Cast Zinc (0.080" nominal)
Interior Brackets	Die Formed Sheet Steel (20 gauge)
Reflectors	White Powder Coated Sheet Steel (22 gauge)
Louvers	Die Formed Semi-Specular Aluminum (22 gauge)
White Louver	Die Formed Aluminum Painted White (22 gauge)
Blank	Extruded Aluminum (0.075" nominal)
Lenses	Extruded Acrylic (0.070" nominal) Satin: 68% trans. Frosted: 85% trans.
Hanger	Die Formed Sheet Steel (18 gauge)
Suspension	Aircraft Cable or Ø 1/2" Stem
Cable Grips	Quick Connecting / Release
Wall Mount Bracket	Die Formed Sheet Steel (16 gauge)
Asymmetric Reflector	Extruded Aluminum (0.075" nominal)
Finish	Anodized, Powder Coated, Lacquered
Weight	16.2 lbs / 7.4 kg (4' fixture)

ELECTRICAL

Ballast Options	Electronic, Dimmable, Emergency
Emergency	Emergency Battery Pack or Circuit
Lamp Options	T5, T5HO, T8
Voltage	120, 277, 347, UNV

Daylight Harvesting / Occupancy Sensors Available

Certification UL listed to U.S. & Canadian standards

PRODUCT ORDERING CODE

product id	optics	length / ft	lamp	lamp config.	MR11	finish	voltage	ballast	circuits	suspension	other	custom
TB	A	8	T5	2	M0	W	120	E	I	CA36		
TB pendant +W wall horizontal	2 3 4 5 6 8 12 S # system		ID one lamp down 2 two lamps (1 up / 1 down)		W white A aluminum C custom		UNV 120 277 347	E electronic ERS rapid start D dimming (specify details)	CA # cable (36" std) CT # cable / t-bar SA # stem (18" std) (length / inch)	C custom description if required		
	A asymmetric reflector		T5 T5HO		M# MR11 qty. * (add 6" per lamp)			1 one circuit 2 two circuits +E em. circuit +M + MR11	D dust cover B# batt. pack (quan./4' sections) F fuse (one per ballast)			
i 7.1, 7.3, 7.4 Installation Instructions Corners: See Twin Beam Corner Spec sheet.	i 4.0 Optics				* Maximum 7 x MR11 lamps per 4' fixture. Provide a sketch for MR11 locations. MR11 : See Twin Beam MR11 Spec sheet.							i 3.0 Mounting Options

DETAILED INFORMATION

for more detailed information, please refer to the info sheets noted above



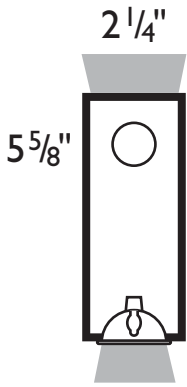

twin BEAM₂

MRII SPECIFICATIONS

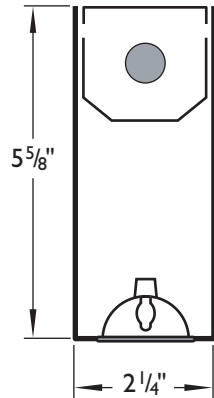

MRII CONFIGURATIONS

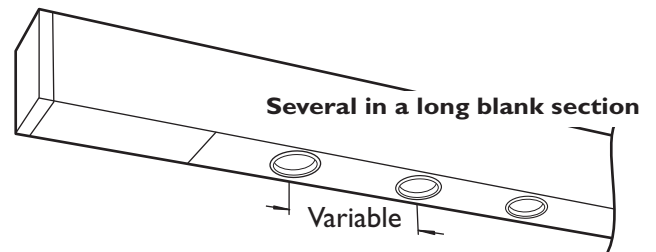
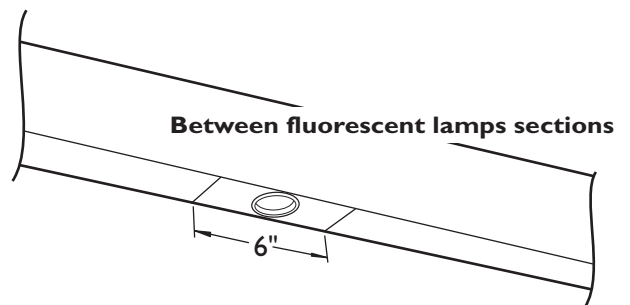
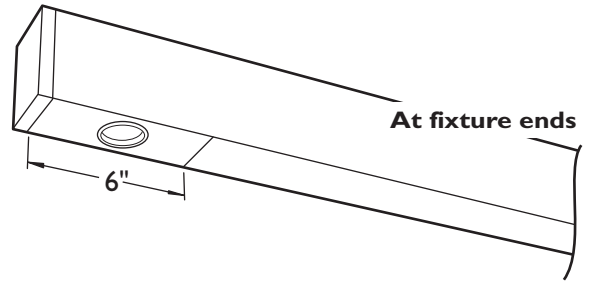

CONSTRUCTION

Blank Extruded Aluminum (0.075" nominal)
MRII Halogens 1.4" diameter

(Uplight lamping is available with MRII Halogens)

*The directed light of MRII Halogen lamps is fixed downward

Quantity

For every 4' fluorescent lamp section, there may be up to a maximum of 7 x MRII lamps.

Spacing

Each MRII is placed centered on a blank section 6" in length.

For a series of MRII's within a given section length, they will be spaced evenly on a longer blank section.

* Custom spacing may be available on special request.

PRODUCT ORDERING CODE

product id	optics	length / ft	lamp	lamp config.	MRII	finish	voltage	ballast	circuits	suspension	other	controls	custom
TB	S	4	T5	IU	M7	W	I20	E	IM	CA36			
TB pendant +W wall horizontal +V wall vertical	S# system S satin lens F frosted lens PL semi spec para.louwer SB white louwer	2 3 4 5 6 8 12	0 zero lamps IU* one lamp up ID one lamp down 2 two lamps (1 up / 1 down)	M# MRII qty. * (add 6" per lamp) Designated area which indicates the quantity of MRII's desired. * Maximum 7 x MRII lamps per 4' fixture. Provide a sketch for MRII locations.	W white A aluminum C custom	UNV 120 277 347	E electronic ERS rapid start D dimming (specify details)	CA # cable (36" std) CT# cable / t-bar SA # stem (18" std) (length / inch)	D dust cover B# batt. pack (quan./4' sections) F fuse (one per ballast)	DS daylight sensor OS occ. sensor DOS daylight / occ. sensor	C custom description (include sketch)		

i 4.0 Optics

i 7.1 7.3 7.4 Installation Instructions
Corners: See Twin Beam Corner Spec sheet.
Vertical: See Twin Beam Vertical Wall Mount Spec sheet.

i DETAILED INFORMATION

for more detailed information, please refer to the info sheets noted above

i 5.0 Control Sensors

Sensors are mounted on a blank sheet of extruded aluminum.

i 3.0 Mounting Options

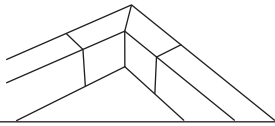

CORNER SPECIFICATIONS

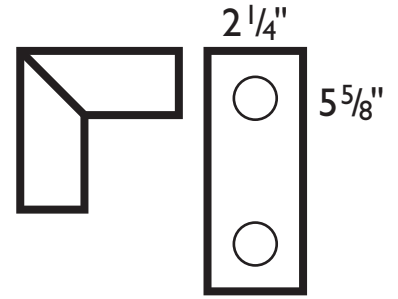

REQUIREMENTS

Corners are to be ordered in parallel with their corresponding linear sections. Please specify each corner style required with a separate code (see code below).

Mounting points are to be situated on attached linear sections as per regular pendants rather than on corners.

All systems requiring corner units must be specified as such at the time of order. Existing linear systems or fixtures cannot have corners added at a later date.

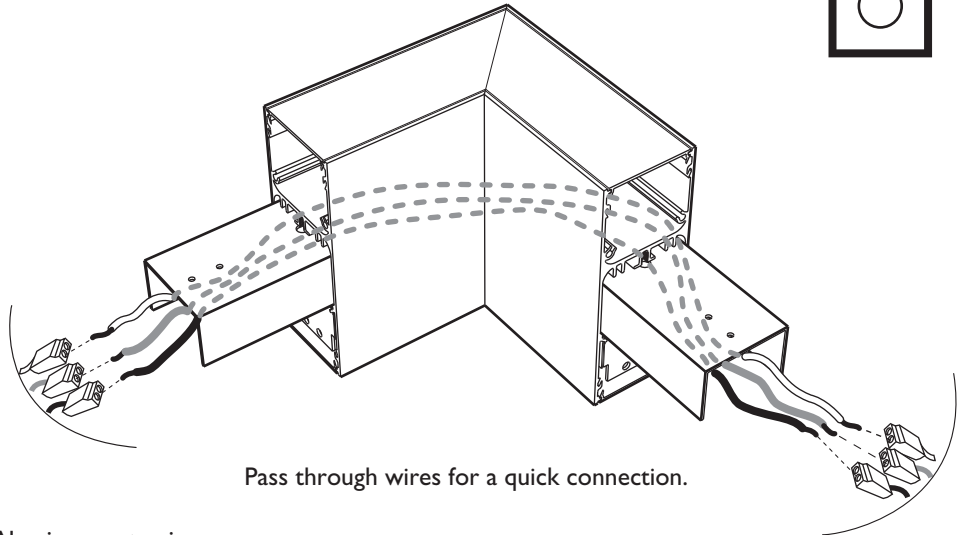

Pass through wires for a quick connection.



CONSTRUCTION

General Assembly	Mitered Aluminum extrusion
Side Profile	Extruded Aluminum (0.100" nominal)
Center Profile	Extruded Aluminum (0.080" nominal)
Interior Brackets	Die Formed Sheet Steel (16 gauge)
Finish	Anodized, Powder Coated, Lacquered
Certification	UL listed to U.S. & Canadian standards

CORNER CONFIGURATIONS

In addition to individual pendants and linear runs, the Twin Beam fixture can be specified with corner 90°, T or X sections.

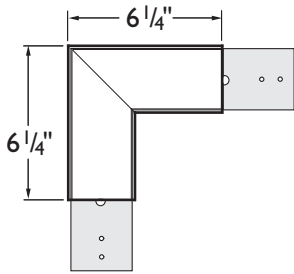

90° Corner
(Corner Option: **C**)

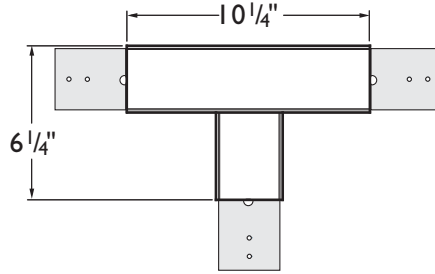

T Corner
(Corner Option: **T**)

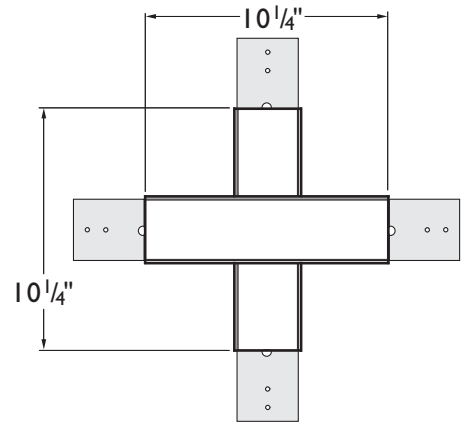

X Corner
(Corner Option: **X**)

TWIN BEAM CORNER ORDERING CODE

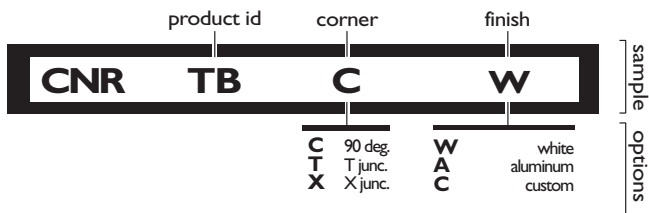

TWIN BEAM CORNER FEATURES

The corner modules are an assembly of welded aluminum extrusions. For added rigidity and a secure joining, the assembly uses an internal extrusion to connect the corners and linear sections of the system.

Wall mounted corners are also available. Please notify Axis with sketch and details.

Corner Specification Tip:

* Provide sketches illustrating corner types and location.

DETAILED INFORMATION

for more detailed information, please refer to the info sheets noted above

